







SUMMER READING COMPREHENSION AND WRITING

IN THIS PACKET YOU WILL FIND 5 STORIES WITH READING COMPREHENSION AND 3 WRITING TASKS. PLEASE COMPLETE ALL PAGES. THE CHECKLIST BELOW IS A GREAT RESOURCE FOR YOUR STUDENT.

5 star writing

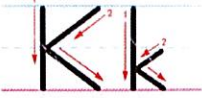
	Capital letter to start my sentence. → I see a dog.
	Punctuation to end my sentence. Where is the dog? ↘
	Use finger spaces. The dog is brown. 
	Use neat handwriting. 
	My sentence makes sense. 

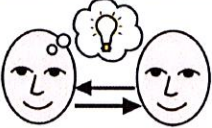
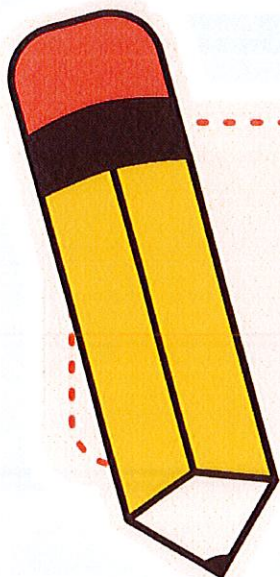

PACING GUIDE

WEEK

1

STORY: DASH AND HIS RED BALL
READ AND COMPLETE COMPREHENSION

2

STORY: BUZZ THE BEE
READ AND COMPLETE COMPREHENSION

3

WRITING
"WHEN I GO TO THE BEACH"

4

STORY: THE FLAT TIRE
READ AND COMPLETE COMPREHENSION

5

WRITING
'WHAT ARE YOUR FAVORITE TREATS...'

6

STORY: THE BIG BUBBLE
READ AND COMPLETE COMPREHENSION

7

STORY: THE WHEEL OF CHEESE
READ AND COMPLETE COMPREHENSION

8

WRITING
'MY FAVORITE THING TO DO DURING SUMMER IS..'

Week 1: Story

Dash and His Red Ball

Dash was a cute dog. One day Dash lost his red ball. Dash was fast, so he worked quickly to find it. He checked under the table, but his ball was not there. He looked outside in the sandbox, but his ball was not there. Dash saw something red by the fence. He ran to see what it was. It was his ball! It had rolled under a bush.

Dash was so excited. His tail wagged and wagged!

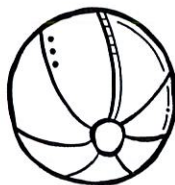

Week 1: Comprehension Questions

Dash and His Red Ball



1 - Which adjectives best describe Dash?

A) slow and silly

B) cute and fast

C) sleepy and cute

D) loud and silly

2 - What is Dash's problem in the story?

3 - Name two places Dash looked for his ball:

4 - Where did Dash find his ball?

5 - How do you know Dash is excited when he finds his ball? Highlight evidence from the story that supports your answer by coloring the evidence green.

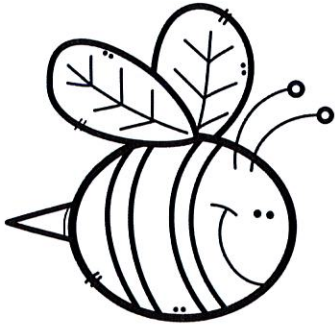

Week 2: Story

Buzz the Bee

Buzz was a honey bee. She loved to fly around in the sun. One day, she flew too far. Buzz got lost. She could not find her way home. Buzz was scared, so she started to cry.

“I will never find my home,” she said.

Just then, Buzz saw purple and yellow flowers on the other side of the yard. “There are yellow and purple flowers like those by my hive,” thought Buzz.

So she flew toward the flowers and Buzz found her hive. She made it home safely.

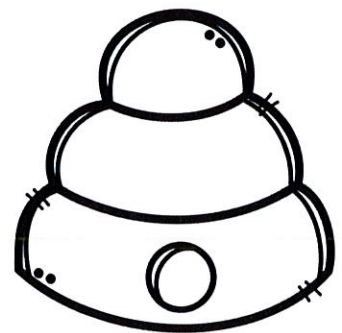

Week 2: Comprehension Questions

Buzz the Bee

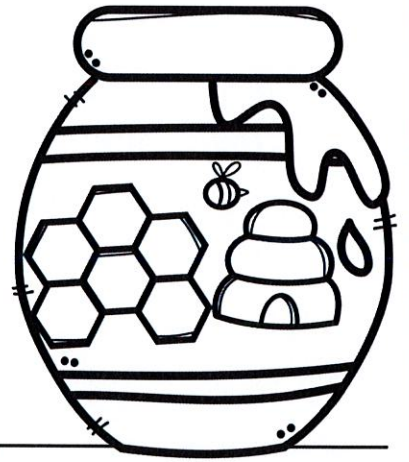

1 - What type of bee was Buzz?

A) a wasp

B) a jacket bee

C) a flying hornet

D) a honey bee

2 - What was Buzz's problem in the story?

3 - How did Buzz find her way back to her hive?

4 - What should Buzz do differently the next time she goes out flying?

5 - How did Buzz feel in the middle of the story? How do you know?

Highlight evidence from the story that supports your answer by coloring the evidence green.

When I go to the beach, my favorite thing to do is...

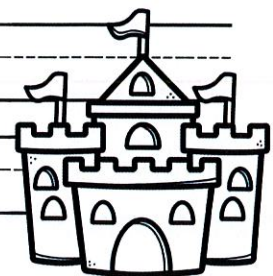
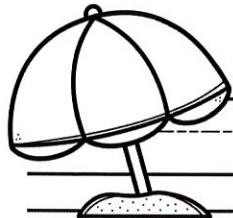

Week 4: Story

The Flat Tire

One day, Dad and I we were driving in the car. We were going to surprise Mom at work with a picnic lunch. We hit a bump in the road and our tire went flat. Dad got out to check it. He found a nail in the tire. Dad was so mad, his face turned red.

“Let’s get the spare tire,” Dad said. We took it out of the trunk.

I told Dad, “I can help.”

The two of us worked together to change the tire. Then, we went and had the picnic lunch with Mom. She was so surprised!

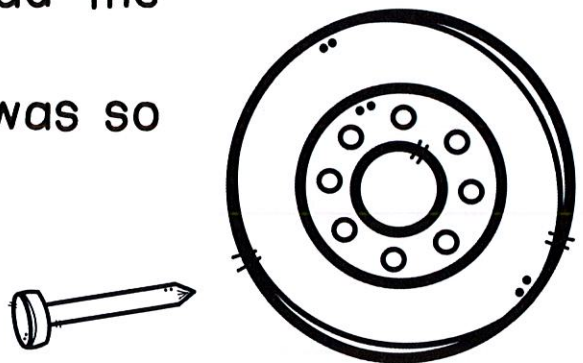

Week 4: Comprehension Questions

The Flat Tire

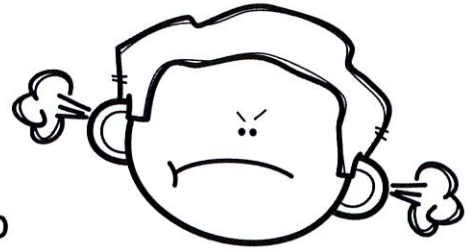

1 - Where were Dad and the narrator going?

A) to the park

B) to the zoo

C) to visit grandpa

D) to surprise Mom with lunch

2 - What was the problem in the story?

3 - How was the problem solved?

4 - What caused the flat tire?

5 - How did Dad feel when they got the flat tire? How can you tell?

Highlight evidence from the story that supports your answer by coloring the evidence green.

What are your favorite treats to eat or drink during the summer...

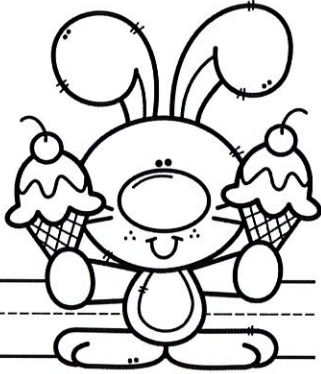

A series of horizontal writing lines for a student to write their answer. Each line set consists of a solid top line, a dashed middle line, and a solid bottom line. There are 10 such sets of lines available for writing.



Week 6: Story

The Big Bubble



Sofia liked to blow bubbles. She would blow them in her chocolate milk. She would blow them outside during the summer. Her favorite thing to do was blow bubbles while chewing gum. The more gum she chewed, the bigger her bubbles would get.

One day, Sofia decided to chew a whole pack of gum so that she could blow the biggest bubble ever! But when the bubble popped, Sofia got gum in her hair! Sofia's mom had to give her a haircut. Now, Sofia only chews one piece of gum at a time.

Week 6: Comprehension Questions

The Big Bubble

1 - In the story, Sofia makes bubbles in every way EXCEPT?

- A) in her milk B) outside during the summer
C) in her bubble bath D) with gum

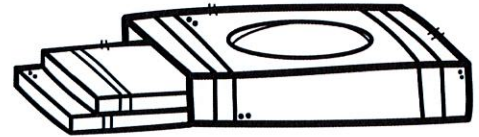

2 - What is Sofia's favorite thing to do?

3 - Why does Sofia decide to chew a whole pack of gum?

4 - What lesson does Sofia learn at the end of the story?

5 - What happened to Sofia because she chewed too much gum at one time? Highlight evidence from the story that supports your answer by coloring the evidence green.

Week 7: Story

The Wheel of Cheese

Phil and Jill were mice. They were brother and sister. They loved to play outside together.

One day, while they were playing, they found a big wheel of cheese.

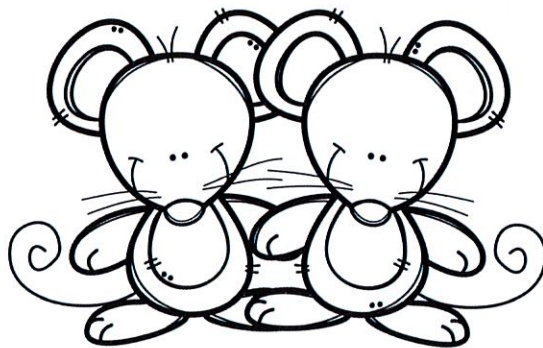

“This is huge!” said Phil.

“It looks so yummy!” said Jill.

Jill and Phil wanted to take the big wheel of cheese home. They tried to pick it up, but it was too heavy to carry. They tried to push the wheel of cheese, but it was too heavy to push. Jill rolled the wheel on its side and then she and Phil rolled it all the way home!

Week 7: Comprehension Questions

The Wheel of Cheese

1 - What were Phil and Jill doing when they found the wheel of cheese?

A) playing together outside

B) eating cheese

C) visiting a friend

D) looking for food

2 - What did Phil say when he saw the wheel of cheese?

3 - What did Jill say when she saw the wheel of cheese?

4 - List 2 ways Phil and Jill tried to get the wheel of cheese home that did NOT work?

5 - How do Phil and Jill finally get the wheel of cheese home? Highlight evidence from the story that supports your answer by coloring the evidence green.

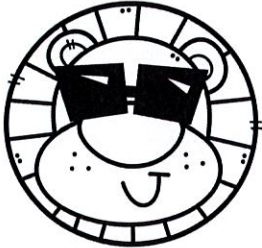

My favorite thing to do during the summer is...

A series of horizontal writing lines for a student to write their answer. Each line set consists of a solid top line, a dashed middle line, and a solid bottom line.



Writing sample

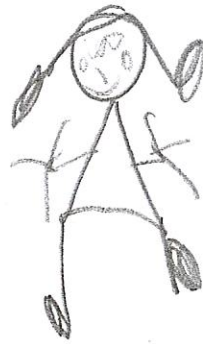

It snowed on Sunday
me and bannia eat
the ice cream and we
have a brain freeze
so we eat some more
ice cream and get more
brain freezes and

So we go see the
Doctor so we don't get
anne mole brain freezes.

Draw

Writing sample



Draw a koala and its baby climbing a tree.



Write

Write about what the koala will do in the tree.

the koalas will
eat leaves in the tree.
The koala will sleep in
the tree. The koala climbed
the tree with the baby
koala.